

REVISIONS				
REV	DATE	DESCRIPTION	CHG	APPR
A	DEC 10 '10	CHG WIRE DIA AND SHAPE.	Y.S.	Y.S.
	JAN 14 '11	CHG NAME (WAS QSZ Z-CL 54SQ AS-P58).	Y.S.	Y.S.
PRODUCTION RELEASE				

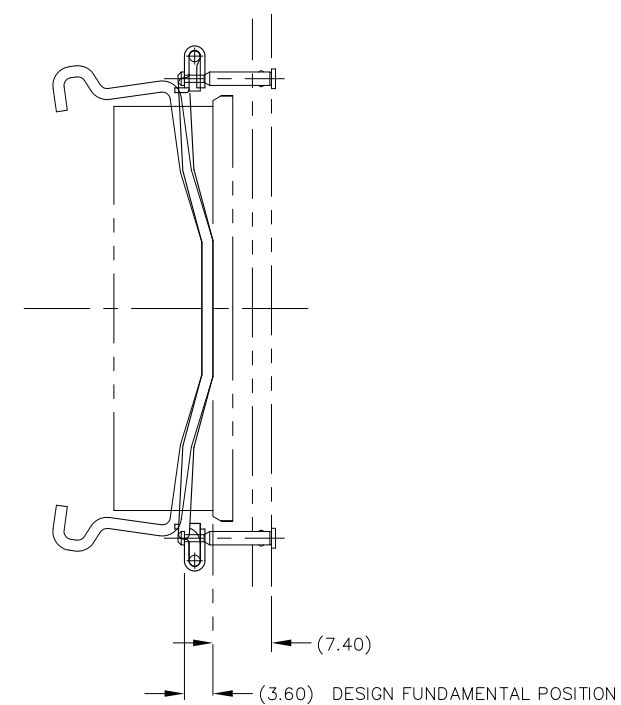
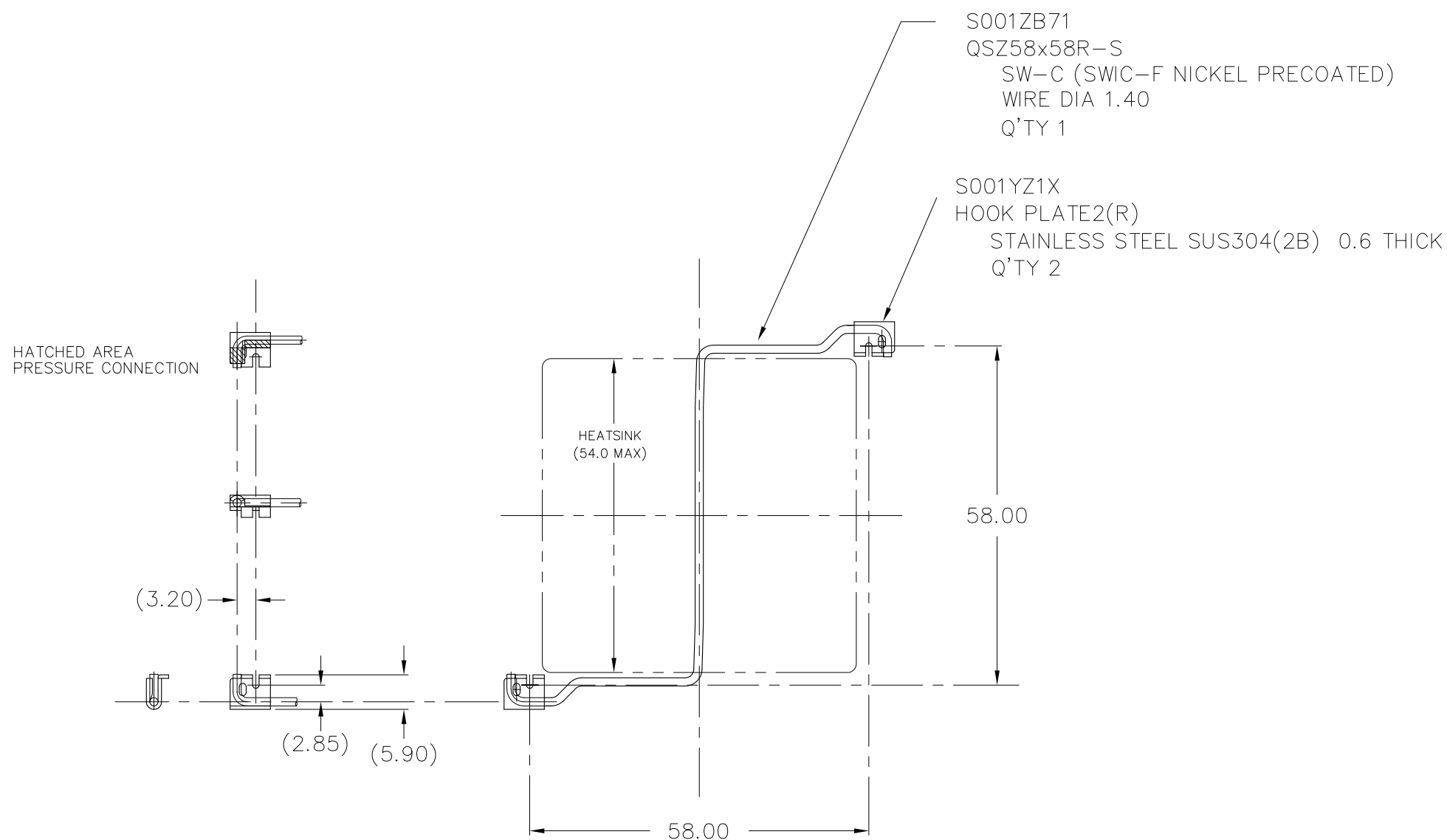

ANCHOR LAYOUT ON BOARD
 REQUIRES $\phi 1.80 \pm 0.05$ THRU HOLES
 FOR ANCHORS IN BOARD.

- NOTES : UNLESS OTHERWISE SPECIFIED
1. INTERPRET DIMENSIONS AND TOLERANCES PER ANSI Y14.5M
 2. ALL DIMENSIONS ARE IN MILLIMETERS.
 3. TOLERANCES :
 .XX ± 0.254
 .XXX ± 0.127
 ANGLES $\pm 3^\circ$

ITEM	PART NO.	PART NAME	REMARK	Q'TY
ALPHA CO.,LTD.		CSTM'R'S PART NO.		
	MATERIAL		NAME	QSZ58x58R
SCALE	APPR & CHCK		PART NO. & DWG NO.	REV
1 : 1	Y.SUZUKI		S001ZB70	A
DATE	DSGN & DWG		RDCTN:	LOFF:
NOV 09. 2010	Y.SUZUKI			