

REVISIONS				
REV	DATE	DESCRIPTION	CHG	APPR

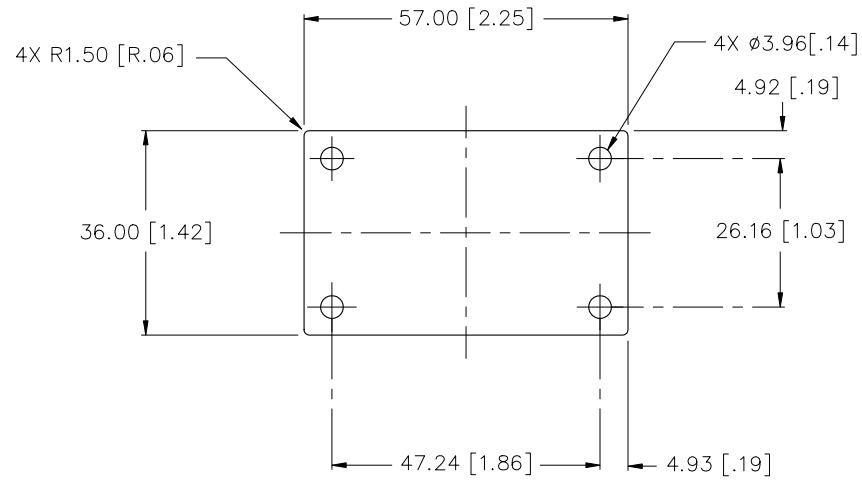

- NOTES : UNLESS OTHERWISE SPECIFIED
- INTERPRET DIMENSIONS AND TOLERANCES PER ANSI Y14.5M
  - ALL DIMENSIONS ARE IN MILLIMETERS.
  - MATERIAL:  
LAIRD TECHNOLOGIES TPCM5125  
0.125[.005"]THK.  
SUPPLIED ON A REMOVABLE LINER SHEET.
  - TOLERANCES :  
.XX ±0.381 [±.015]

ITEM	PART NO.	PART NAME	REMARK	Q'TY
<b>ALPHA CO.,LTD.</b>			CSTM'R'S PART NO.	
		MATERIAL SEE NOTE 3	NAME TPCM5125-QB	
SCALE 1 : 1		APPR & CHCK M. YAMAMOTO	PART NO. & DWG NO. S001XSDY	REV
DATE SEP 14. 2023		DSGN & DWG M. YAMAMOTO	RDCTN:	LOFF: