

ALPHA

for Nehalem

U90C-27NT

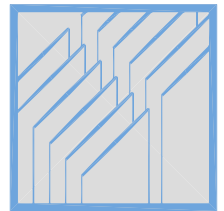

DIM

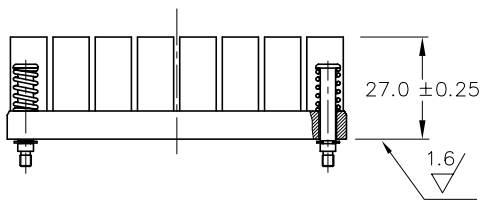
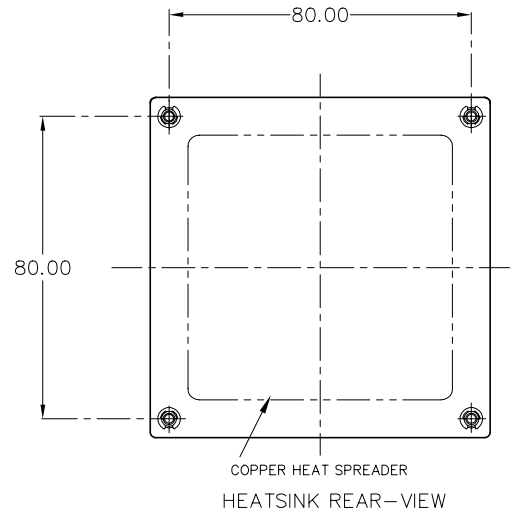
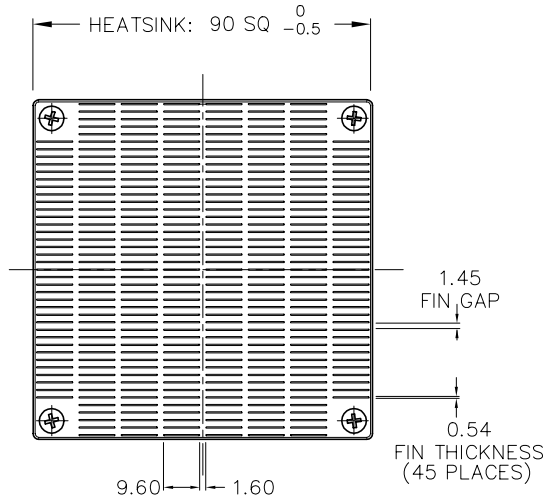

- HEAT SINK
MATERIAL : A 6063
COPPER EMBEDDED
FINISH : NONE
- CAPTIVE SPRING SCREW
SHOULDER-SCREW
STEEL ZINC/CHROMATE(Cr3+)
SPRING
SWP-B ZINC/CHROMATE(Cr3+)
E-RETAINING RING
STAINLESS STEEL
- TOTAL WEIGHT: 394 g

DIMENSIONS : mm

DATA

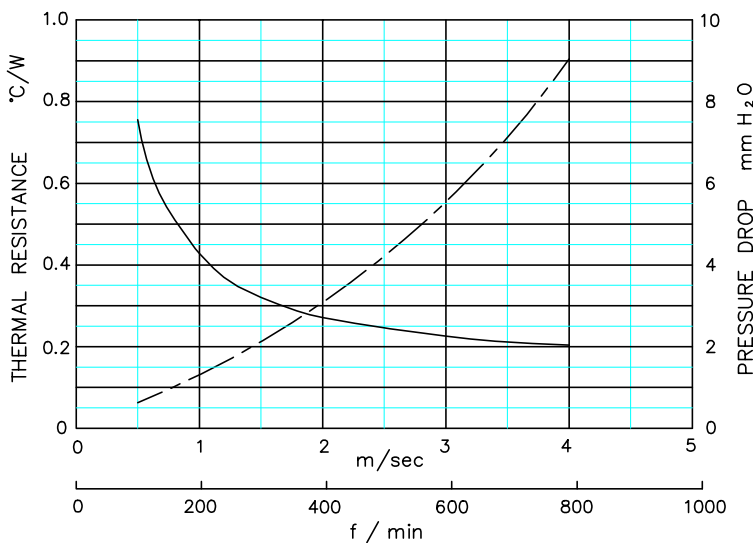

U90C-27NT

- DUCTED CONDITION
THERMAL RESISTANCE (solid line)
PRESSURE DROP (dashed line)

■ BASED ON ALPHA'S STANDARD TEST PROCEDURE.
REFER TO TECHNICAL INFORMATION.

Alpha Company Ltd.

256-1 UEDA, NUMAZU-CITY SHIZUOKA-PREF., JAPAN
PHONE +81(55)966 0789
FAX +81(55)966 9192
E mail : alpha@micforg.co.jp
URL : <http://www.micforg.co.jp>

Alpha Novatech, Inc. - a subsidiary of Alpha Company.

473 Sapena Ct. #12 Santa Clara, CA 95054 USA
PHONE +1(408)567-8082
FAX +1(408)567-8053
E mail : sales@alphanovatech.com
URL : <http://www.alphanovatech.com>