

# ALPHA

# U90C-25NT-2011

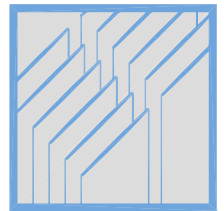

DIM

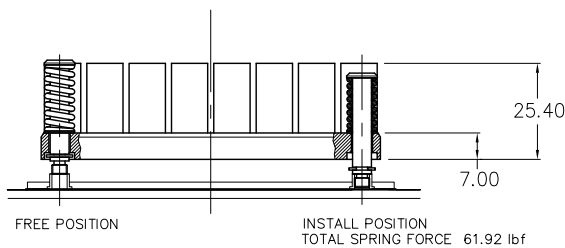
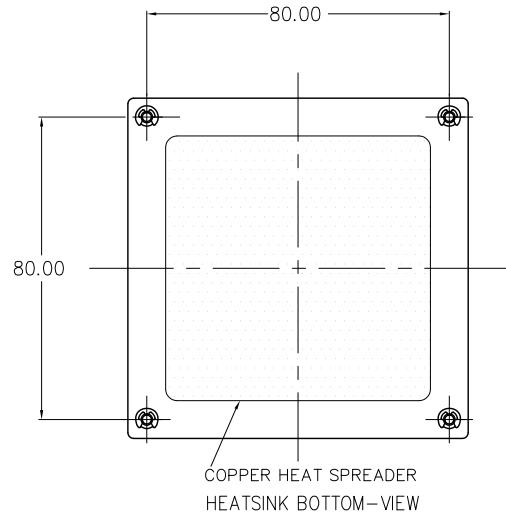
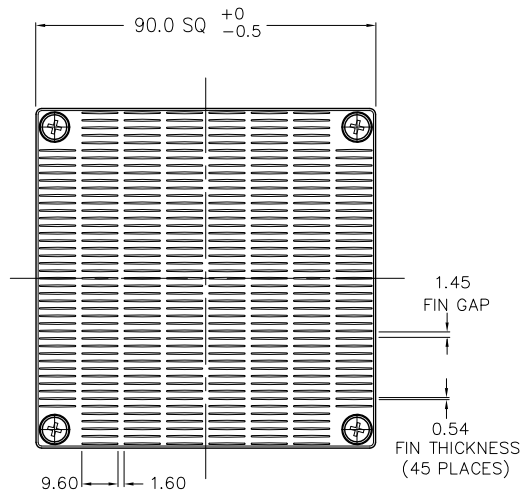

- HEAT SINK  
MATERIAL : A 6063  
COPPER EMBEDDED  
FINISH : NONE
- CAPTIVE SPRING SCREW  
SHOULDER-SCREW  
STEEL ZINC/CHROMATE(Cr3+)  
SPRING  
SWP-A ZINC/CHROMATE(Cr3+)  
E-RETAINING RING  
STAINLESS STEEL  
WASHER  
STAINLESS STEEL

■ TOTAL WEIGHT 360g

DIMENSIONS : mm

DATA

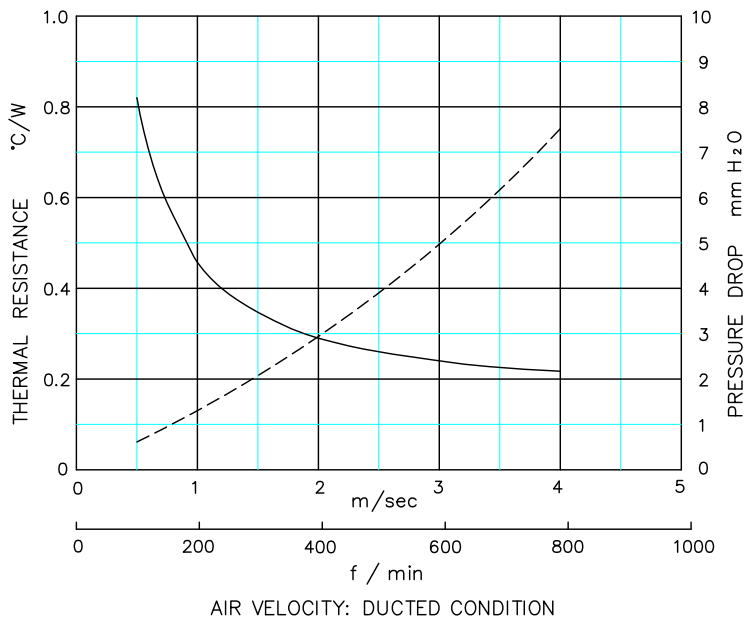

U90C-25NT-2011

- DUCTED CONDITION
- THERMAL RESISTANCE
- - - PRESSURE DROP

■ BASED ON ALPHA'S STANDARD TEST PROCEDURE.  
REFER TO TECHNICAL INFORMATION.

Alpha Company Ltd.

256-1 UEDA, NUMAZU-CITY SHIZUOKA-PREF., JAPAN  
 PHONE +81(55)966 0789  
 FAX +81(55)966 9192  
 E mail : alpha@micforg.co.jp  
 URL : http://www.micforg.co.jp

Alpha Novatech, Inc. - a subsidiary of Alpha Company.

473 Sapena Ct. #12 Santa Clara, CA 95054 USA  
 PHONE +1(408)567-8082  
 FAX +1(408)567-8053  
 E mail : sales@alphanovatech.com  
 URL : http://www.alphanovatech.com