

QuickSet Series
QUBR

ALPHA

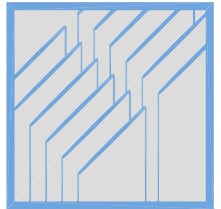

DIM

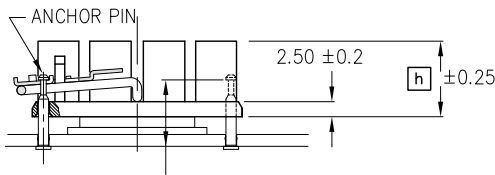
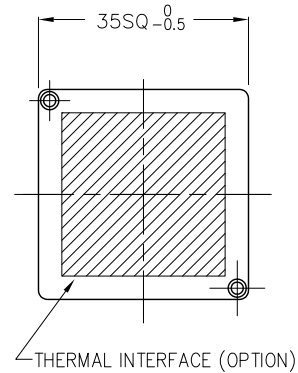
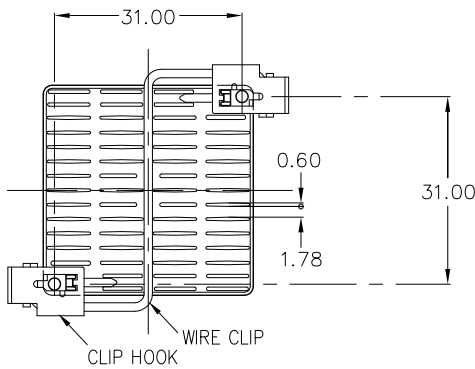

ANCHOR PIN LENGTH : CAN SELECT 8.00, 11.00, 13.00, OR 16.00.

8.00 : ANCR-8

11.00 : ANCR-11

13.00 : ANCR-13

16.00 : ANCR-16

ATTACHMENT FORCE : REFER TO THE ● CLIP FORCE.

MATERIAL

HEATSINK : A6063 BLACK ANODIZE

WIRE CLIP : SW-C NICKEL PRECOATED

HOOK : STAINLESS STEEL 304

ANCHOR : STAINLESS STEEL 303

DIMENSIONS : mm

BASIC HEATSINK MODEL NUMBER	OVERALL HEIGHT [h]	BASIC HEATSINK WEIGHT (grams)	FEATURES
QUBR35-10B	10	12.7	FOR FORCED CONVECTION HIGH PERFORMANCE HEATSINK. LOW PRESSURE DROP.
QUBR35-15B	15	15.4	
QUBR35-20B	20	18.1	
QUBR35-25B	25	20.8	

● PCB HOLE PATTERN & SUGGESTED KEEP-OUT AREA

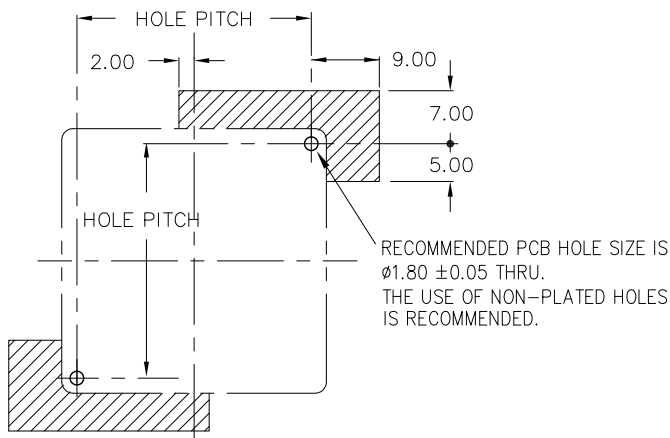

● CLIP FORCE

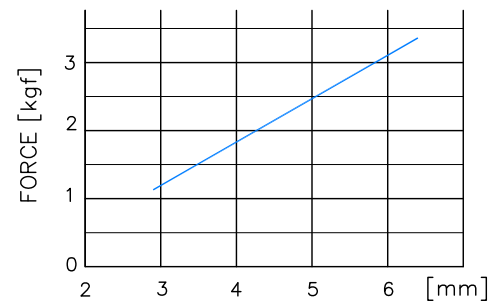

ANCR-8 : CHIP HEIGHT + PCB THK + 3.0

ANCR-11 : CHIP HEIGHT + PCB THK

ANCR-13 : CHIP HEIGHT + PCB THK - 2.0

ANCR-16 : CHIP HEIGHT + PCB THK - 5.0

Alpha Company Ltd.

256-1 UEDA, NUMAZU-CITY SHIZUOKA-PREF., JAPAN

PHONE +81(55)966 0789

FAX +81(55)966 9192

E mail : alpha@micforg.co.jp

URL : <http://www.micforg.co.jp>

Alpha Novatech, Inc. - a subsidiary of Alpha Company.

473 Sapena Ct. #12 Santa Clara, CA 95054 USA

PHONE +1(408)567-8082

FAX +1(408)567-8053

E mail : sales@alphanovatech.com

URL : <http://www.alphanovatech.com>

DATA

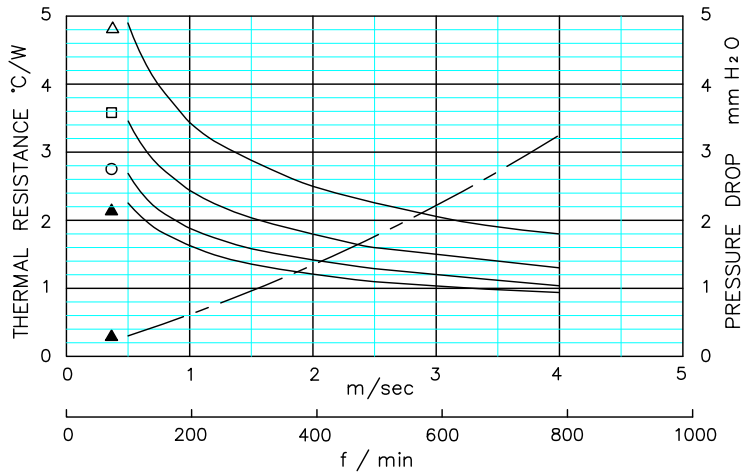

- △ QUBR35-10B
- QUBR35-15B
- QUBR35-20B
- ▲ QUBR35-25B

● DUCTED CONDITION
 DUMMY HEATER SIZE: 12.7 SQ
 THERMAL RESISTANCE _____
 PRESURE DROP - - - - -

■ BASED ON ALPHA'S STANDARD TEST PROCEDURE.
 REFER TO TECHNICAL INFORMATION.

AIR VELOCITY: DUCTED CONDITION

REF



MODEL NAME INFORMATION

TO BUILD PART NUMBER, PLEASE VISIT OUR WEBSITE www.micforg.co.jp OR CONTACT ALPHA SALES.

Alpha Company Ltd.

256-1 UEDA, NUMAZU-CITY SHIZUOKA-PREF., JAPAN
 PHONE +81(55)966 0789
 FAX +81(55)966 9192
 E mail : alpha@micforg.co.jp
 URL : <http://www.micforg.co.jp>

Alpha Novatech, Inc. - a subsidiary of Alpha Company.

473 Sapena Ct. #12 Santa Clara, CA 95054 USA
 PHONE +1(408)567-8082
 FAX +1(408)567-8053
 E mail : sales@alphanovatech.com
 URL : <http://www.alphanovatech.com>

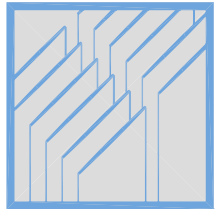

DIM

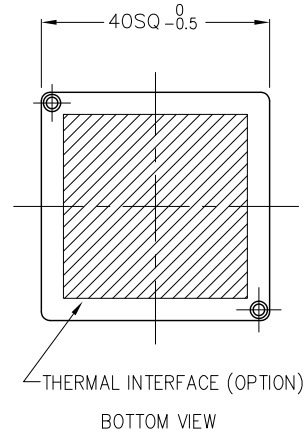
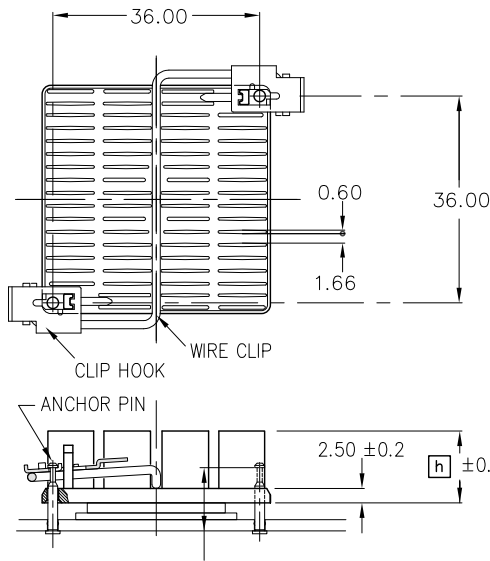

ANCHOR PIN LENGTH : CAN SELECT 8.00, 11.00, 13.00, OR 16.00.

8.00 : ANCR-8

11.00 : ANCR-11

13.00 : ANCR-13

16.00 : ANCR-16

ATTACHMENT FORCE : REFER TO THE ● CLIP FORCE.

MATERIAL

HEATSINK : A6063 BLACK ANODIZE

WIRE CLIP : SW-C NICKEL PRECOATED

HOOK : STAINLESS STEEL 304

ANCHOR : STAINLESS STEEL 303

DIMENSIONS : mm

BASIC HEATSINK MODEL NUMBER	OVERALL HEIGHT [h]	BASIC HEATSINK WEIGHT (grams)	FEATURES
QUBR40-10B	10	17.0	FOR FORCED CONVECTION HIGH PERFORMANCE HEATSINK. LOW PRESSURE DROP.
QUBR40-15B	15	21.0	
QUBR40-20B	20	25.0	
QUBR40-25B	25	29.0	

● PCB HOLE PATTERN & SUGGESTED KEEP-OUT AREA

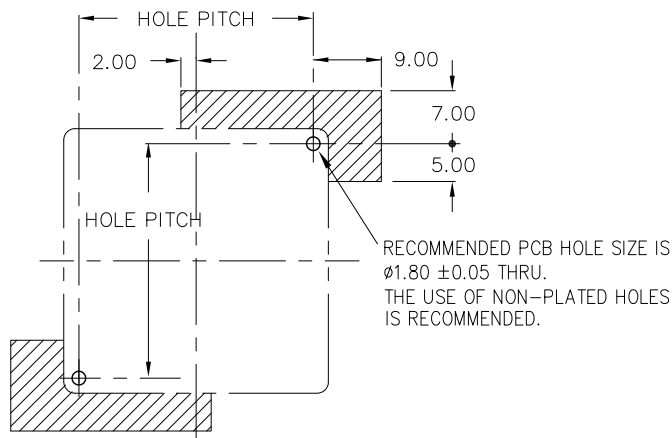

● CLIP FORCE

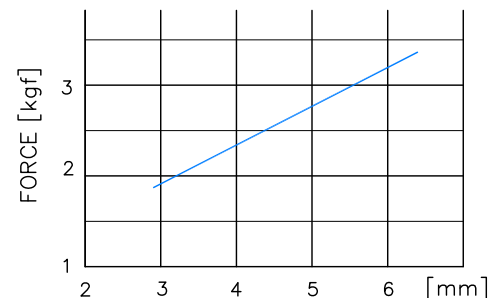

ANCR-8 : CHIP HEIGHT + PCB THK + 3.0

ANCR-11 : CHIP HEIGHT + PCB THK

ANCR-13 : CHIP HEIGHT + PCB THK - 2.0

ANCR-16 : CHIP HEIGHT + PCB THK - 5.0

Alpha Company Ltd.

256-1 UEDA, NUMAZU-CITY SHIZUOKA-PREF., JAPAN

PHONE +81(55)966 0789

FAX +81(55)966 9192

E mail : alpha@micforg.co.jp

URL : http://www.micforg.co.jp

Alpha Novatech, Inc. - a subsidiary of Alpha Company.

473 Sapena Ct. #12 Santa Clara, CA 95054 USA

PHONE +1(408)567-8082

FAX +1(408)567-8053

E mail : sales@alphanovatech.com

URL : http://www.alphanovatech.com

DATA

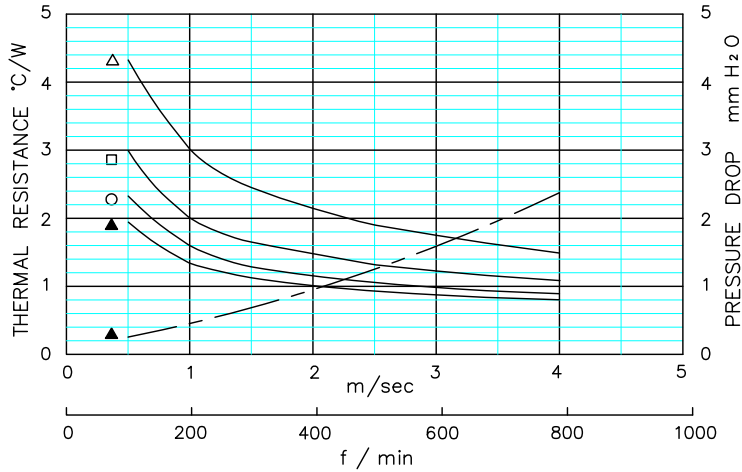

- △ QUBR40-10B
- QUBR40-15B
- QUBR40-20B
- ▲ QUBR40-25B

- DUCTED CONDITION
DUMMY HEATER SIZE: 12.7 SQ
THERMAL RESISTANCE _____
PRESURE DROP - - - - -
- BASED ON ALPHA'S STANDARD TEST PROCEDURE.
REFER TO TECHNICAL INFORMATION.

AIR VELOCITY: DUCTED CONDITION

REF



MODEL NAME INFORMATION
TO BUILD PART NUMBER, PLEASE VISIT OUR WEBSITE www.micforg.co.jp OR CONTACT ALPHA SALES.

Alpha Company Ltd.

256-1 UEDA, NUMAZU-CITY SHIZUOKA-PREF., JAPAN
PHONE +81(55)966 0789
FAX +81(55)966 9192
E mail : alpha@micforg.co.jp
URL : <http://www.micforg.co.jp>

Alpha Novatech, Inc. - a subsidiary of Alpha Company.

473 Sapena Ct. #12 Santa Clara, CA 95054 USA
PHONE +1(408)567-8082
FAX +1(408)567-8053
E mail : sales@alphanovatech.com
URL : <http://www.alphanovatech.com>

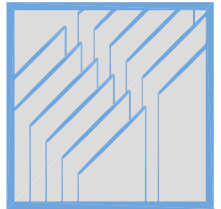

DIM

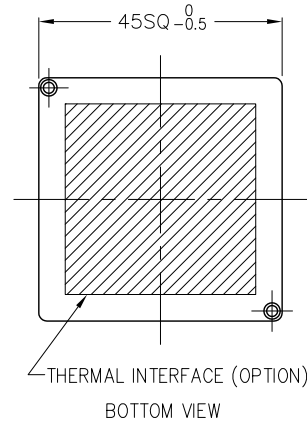
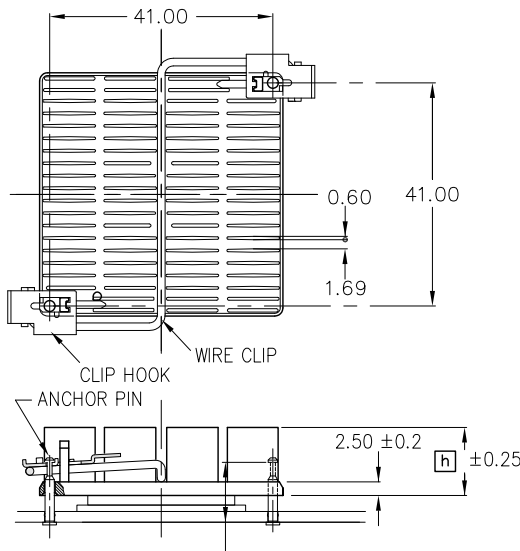

ANCHOR PIN LENGTH : CAN SELECT 8.00, 11.00, 13.00, OR 16.00.

- 8.00 : ANCR-8
- 11.00 : ANCR-11
- 13.00 : ANCR-13
- 16.00 : ANCR-16

ATTACHMENT FORCE : REFER TO THE ● CLIP FORCE.

- MATERIAL
- HEATSINK : A6063 BLACK ANODIZE
- WIRE CLIP : SW-C NICKEL PRECOATED
- HOOK : STAINLESS STEEL 304
- ANCHOR : STAINLESS STEEL 303

DIMENSIONS : mm

BASIC HEATSINK MODEL NUMBER	OVERALL HEIGHT [h]	BASIC HEATSINK WEIGHT (grams)	FEATURES
QUBR45-10B	10	21.9	FOR FORCED CONVECTION HIGH PERFORMANCE HEATSINK. LOW PRESSURE DROP.
QUBR45-15B	15	27.2	
QUBR45-20B	20	32.5	
QUBR45-25B	25	37.8	

● PCB HOLE PATTERN & SUGGESTED KEEP-OUT AREA

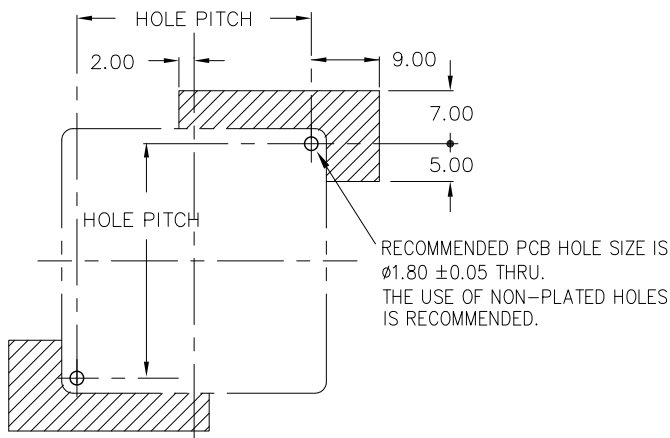

● CLIP FORCE

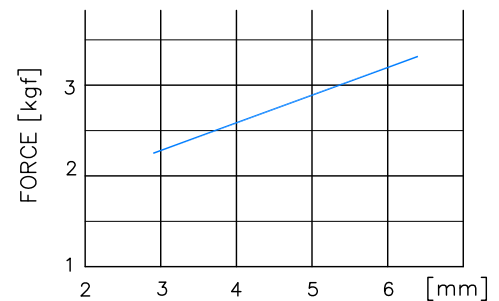

- ANCR-8 : CHIP HEIGHT + PCB THK + 3.0
- ANCR-11 : CHIP HEIGHT + PCB THK
- ANCR-13 : CHIP HEIGHT + PCB THK - 2.0
- ANCR-16 : CHIP HEIGHT + PCB THK - 5.0

Alpha Company Ltd.

256-1 UEDA, NUMAZU-CITY SHIZUOKA-PREF., JAPAN
 PHONE +81(55)966 0789
 FAX +81(55)966 9192
 E mail : alpha@micforg.co.jp
 URL : http://www.micforg.co.jp

Alpha Novatech, Inc. - a subsidiary of Alpha Company.

473 Sapena Ct. #12 Santa Clara, CA 95054 USA
 PHONE +1(408)567-8082
 FAX +1(408)567-8053
 E mail : sales@alphanovatech.com
 URL : http://www.alphanovatech.com

DATA

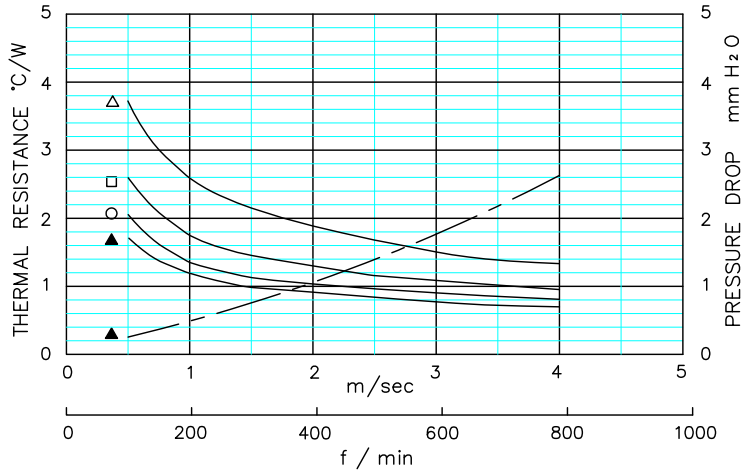

- △ QUBR45-10B
- QUBR45-15B
- QUBR45-20B
- ▲ QUBR45-25B

- DUCTED CONDITION
DUMMY HEATER SIZE: 12.7 SQ
THERMAL RESISTANCE _____
PRESURE DROP - - - - -
- BASED ON ALPHA'S STANDARD TEST PROCEDURE.
REFER TO TECHNICAL INFORMATION.

AIR VELOCITY: DUCTED CONDITION

REF



MODEL NAME INFORMATION
TO BUILD PART NUMBER, PLEASE VISIT OUR WEBSITE www.micforg.co.jp OR CONTACT ALPHA SALES.

Alpha Company Ltd.

256-1 UEDA, NUMAZU-CITY SHIZUOKA-PREF., JAPAN
PHONE +81(55)966 0789
FAX +81(55)966 9192
E mail : alpha@micforg.co.jp
URL : <http://www.micforg.co.jp>

Alpha Novatech, Inc. - a subsidiary of Alpha Company.

473 Sapena Ct. #12 Santa Clara, CA 95054 USA
PHONE +1(408)567-8082
FAX +1(408)567-8053
E mail : sales@alphanovatech.com
URL : <http://www.alphanovatech.com>

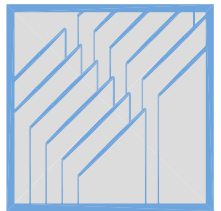

DIM

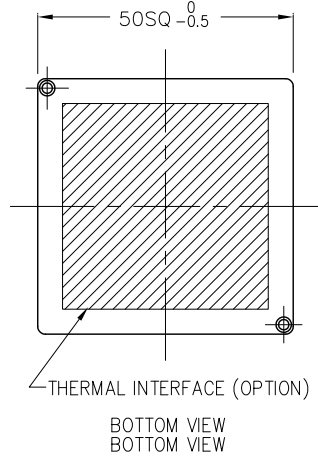
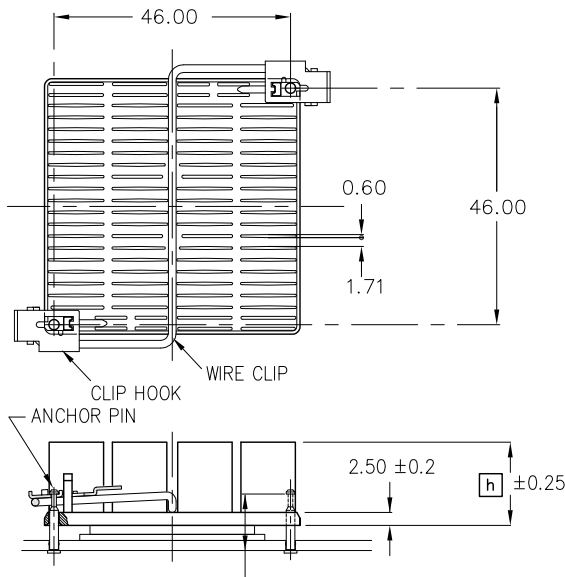

ANCHOR PIN LENGTH : CAN SELECT 8.00, 11.00, 13.00, OR 16.00.

- 8.00 : ANCR-8
- 11.00 : ANCR-11
- 13.00 : ANCR-13
- 16.00 : ANCR-16

ATTACHMENT FORCE : REFER TO THE ● CLIP FORCE.

- MATERIAL
- HEATSINK : A6063 BLACK ANODIZE
- WIRE CLIP : SW-C NICKEL PRECOATED
- HOOK : STAINLESS STEEL 304
- ANCHOR : STAINLESS STEEL 303

DIMENSIONS : mm

BASIC HEATSINK MODEL NUMBER	OVERALL HEIGHT [h]	BASIC HEATSINK WEIGHT (grams)	FEATURES
QUBR50-10B	10	27.7	FOR FORCED CONVECTION HIGH PERFORMANCE HEATSINK. LOW PRESSURE DROP.
QUBR50-15B	15	34.6	
QUBR50-20B	20	41.5	
QUBR50-25B	25	48.4	

● PCB HOLE PATTERN & SUGGESTED KEEP-OUT AREA

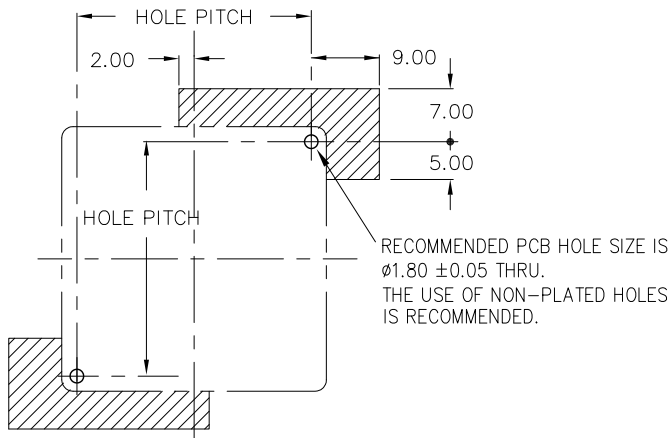

● CLIP FORCE

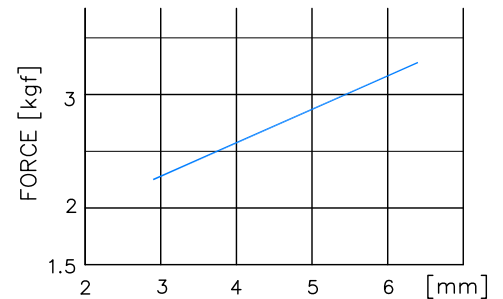

- ANCR-8 : CHIP HEIGHT + PCB THK + 3.0
- ANCR-11 : CHIP HEIGHT + PCB THK
- ANCR-13 : CHIP HEIGHT + PCB THK - 2.0
- ANCR-16 : CHIP HEIGHT + PCB THK - 5.0

Alpha Company Ltd.

256-1 UEDA, NUMAZU-CITY SHIZUOKA-PREF., JAPAN
 PHONE +81(55)966 0789
 FAX +81(55)966 9192
 E mail : alpha@micforg.co.jp
 URL : http://www.micforg.co.jp

Alpha Novatech, Inc. - a subsidiary of Alpha Company.

473 Sapena Ct. #12 Santa Clara, CA 95054 USA
 PHONE +1(408)567-8082
 FAX +1(408)567-8053
 E mail : sales@alphanovatech.com
 URL : http://www.alphanovatech.com

DATA

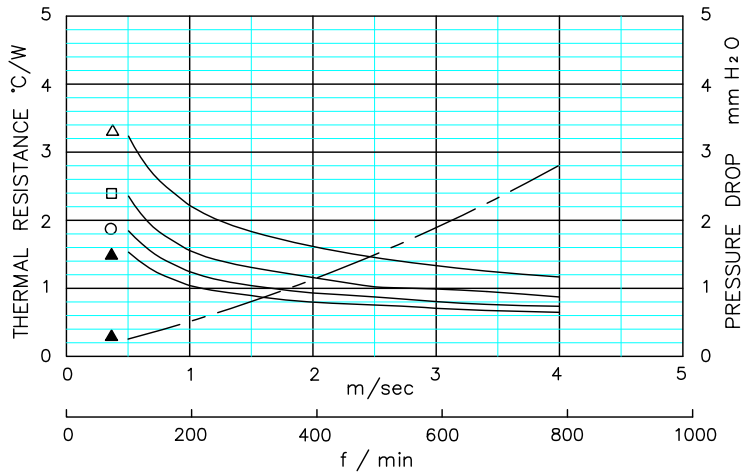

AIR VELOCITY: DUCTED CONDITION

- △ QUBR50-10B
- QUBR50-15B
- QUBR50-20B
- ▲ QUBR50-25B

- DUCTED CONDITION
DUMMY HEATER SIZE: 12.7 SQ
THERMAL RESISTANCE _____
PRESURE DROP - - - - -
- BASED ON ALPHA'S STANDARD TEST PROCEDURE.
REFER TO TECHNICAL INFORMATION.

REF



MODEL NAME INFORMATION
TO BUILD PART NUMBER, PLEASE VISIT OUR WEBSITE www.micforg.co.jp OR CONTACT ALPHA SALES.

Alpha Company Ltd.

256-1 UEDA, NUMAZU-CITY SHIZUOKA-PREF., JAPAN
 PHONE +81(55)966 0789
 FAX +81(55)966 9192
 E mail : alpha@micforg.co.jp
 URL : <http://www.micforg.co.jp>

Alpha Novatech, Inc. - a subsidiary of Alpha Company.

473 Sapena Ct. #12 Santa Clara, CA 95054 USA
 PHONE +1(408)567-8082
 FAX +1(408)567-8053
 E mail : sales@alphanovatech.com
 URL : <http://www.alphanovatech.com>

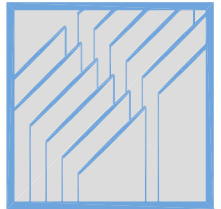

DIM

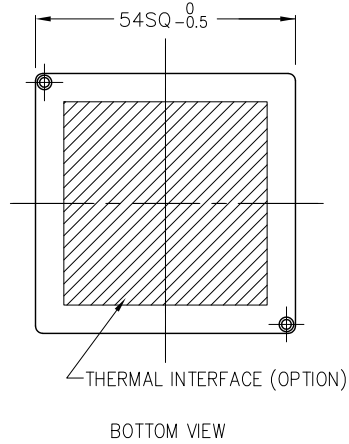
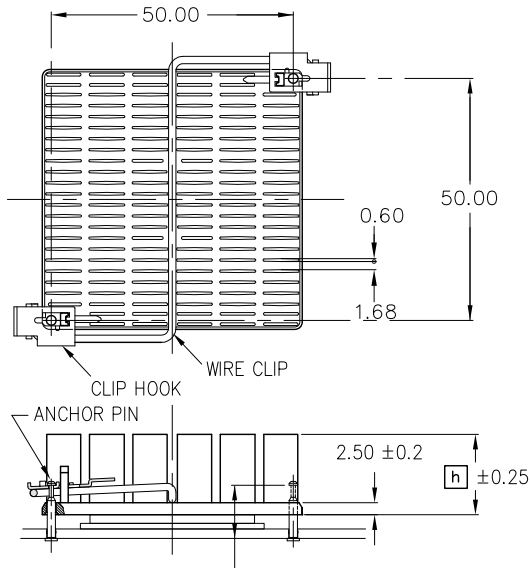

ANCHOR PIN LENGTH : CAN SELECT 8.00, 11.00, 13.00, OR 16.00.
 8.00 : ANCR-8
 11.00 : ANCR-11
 13.00 : ANCR-13
 16.00 : ANCR-16

ATTACHMENT FORCE : REFER TO THE ● CLIP FORCE.

MATERIAL
 HEATSINK : A6063 BLACK ANODIZE
 WIRE CLIP : SW-C NICKEL PRECOATED
 HOOK : STAINLESS STEEL 304
 ANCHOR : STAINLESS STEEL 303

DIMENSIONS : mm

BASIC HEATSINK MODEL NUMBER	OVERALL HEIGHT [h]	BASIC HEATSINK WEIGHT (grams)	FEATURES
QUBR54-10B	10	31.7	FOR FORCED CONVECTION HIGH PERFORMANCE HEATSINK. LOW PRESSURE DROP.
QUBR54-15B	15	39.2	
QUBR54-20B	20	46.7	
QUBR54-25B	25	54.2	

● PCB HOLE PATTERN & SUGGESTED KEEP-OUT AREA

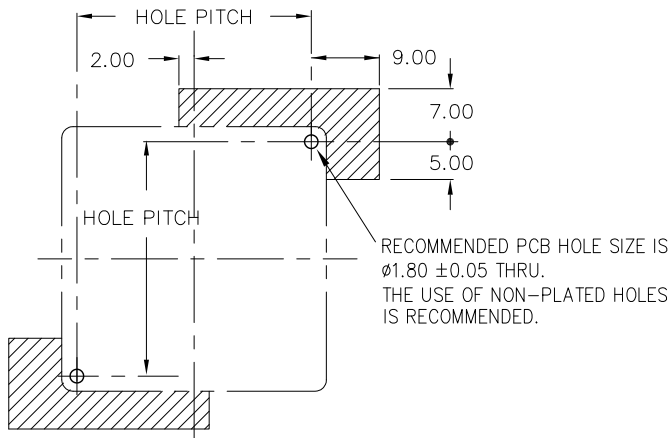

● CLIP FORCE

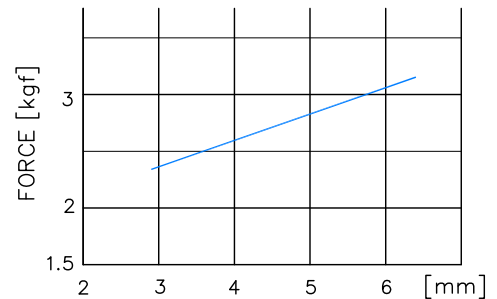

ANCR-8 : CHIP HEIGHT + PCB THK + 3.0
 ANCR-11 : CHIP HEIGHT + PCB THK
 ANCR-13 : CHIP HEIGHT + PCB THK - 2.0
 ANCR-16 : CHIP HEIGHT + PCB THK - 5.0

Alpha Company Ltd.

256-1 UEDA, NUMAZU-CITY SHIZUOKA-PREF., JAPAN
 PHONE +81(55)966 0789
 FAX +81(55)966 9192
 E mail : alpha@micforg.co.jp
 URL : http://www.micforg.co.jp

Alpha Novatech, Inc. - a subsidiary of Alpha Company.

473 Sapena Ct. #12 Santa Clara, CA 95054 USA
 PHONE +1(408)567-8082
 FAX +1(408)567-8053
 E mail : sales@alphanovatech.com
 URL : http://www.alphanovatech.com

DATA

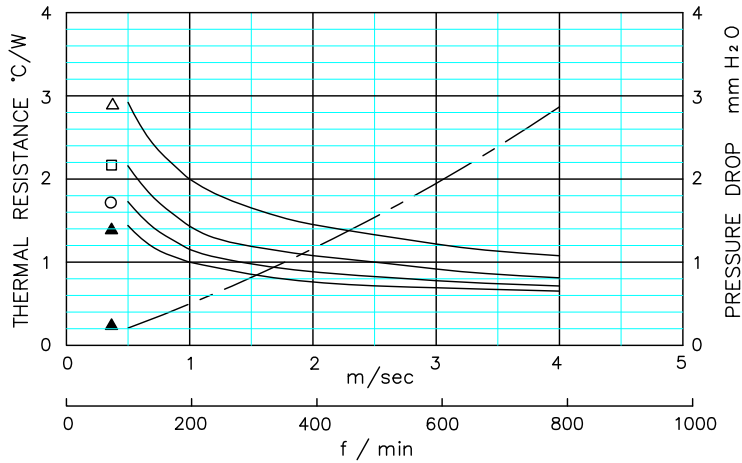

- △ QUBR54-10B
- QUBR54-15B
- QUBR54-20B
- ▲ QUBR54-25B

- DUCTED CONDITION
DUMMY HEATER SIZE: 12.7 SQ
THERMAL RESISTANCE _____
PRESURE DROP - - - - -
- BASED ON ALPHA'S STANDARD TEST PROCEDURE.
REFER TO TECHNICAL INFORMATION.

AIR VELOCITY: DUCTED CONDITION

REF



MODEL NAME INFORMATION

TO BUILD PART NUMBER, PLEASE VISIT OUR WEBSITE www.micforg.co.jp OR CONTACT ALPHA SALES.

Alpha Company Ltd.

256-1 UEDA, NUMAZU-CITY SHIZUOKA-PREF., JAPAN
 PHONE +81(55)966 0789
 FAX +81(55)966 9192
 E mail : alpha@micforg.co.jp
 URL : <http://www.micforg.co.jp>

Alpha Novatech, Inc. - a subsidiary of Alpha Company.

473 Sapena Ct. #12 Santa Clara, CA 95054 USA
 PHONE +1(408)567-8082
 FAX +1(408)567-8053
 E mail : sales@alphanovatech.com
 URL : <http://www.alphanovatech.com>

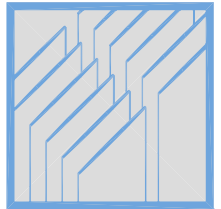

DIM

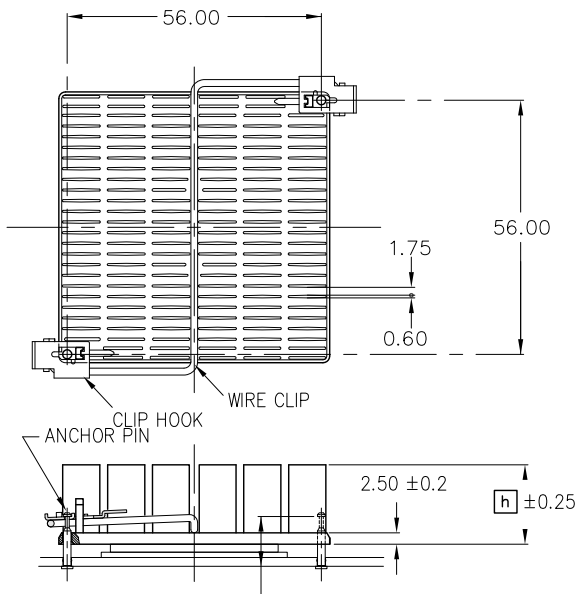

ANCHOR PIN LENGTH : CAN SELECT 8.00, 11.00, 13.00, OR 16.00.
 8.00 : ANCR-8
 11.00 : ANCR-11
 13.00 : ANCR-13
 16.00 : ANCR-16

ATTACHMENT FORCE : REFER TO THE ● CLIP FORCE.

MATERIAL
 HEATSINK : A6063 BLACK ANODIZE
 WIRE CLIP : SW-C NICKEL PRECOATED
 HOOK : STAINLESS STEEL 304
 ANCHOR : STAINLESS STEEL 303

DIMENSIONS : mm

BASIC HEATSINK MODEL NUMBER	OVERALL HEIGHT [h]	BASIC HEATSINK WEIGHT (grams)	FEATURES
QUBR60-10B	10	38.6	FOR FORCED CONVECTION HIGH PERFORMANCE HEATSINK. LOW PRESSURE DROP.
QUBR60-15B	15	47.4	
QUBR60-20B	20	56.2	
QUBR60-25B	25	65	

● PCB HOLE PATTERN & SUGGESTED KEEP-OUT AREA

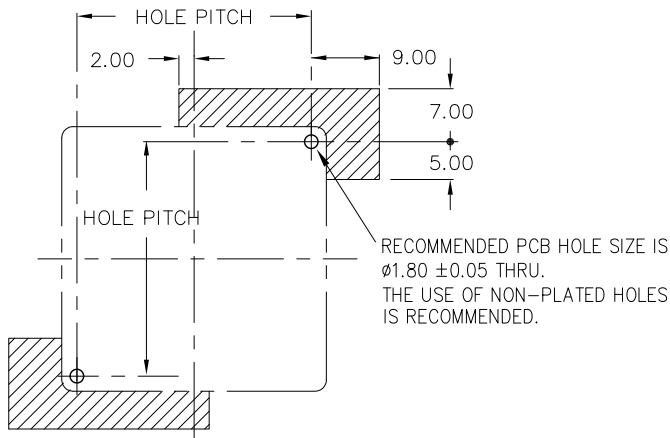

● CLIP FORCE

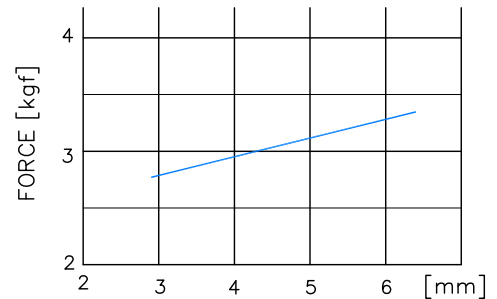

ANCR-8 : CHIP HEIGHT + PCB THK + 3.0
 ANCR-11 : CHIP HEIGHT + PCB THK
 ANCR-13 : CHIP HEIGHT + PCB THK - 2.0
 ANCR-16 : CHIP HEIGHT + PCB THK - 5.0

Alpha Company Ltd.

256-1 UEDA, NUMAZU-CITY SHIZUOKA-PREF., JAPAN
 PHONE +81(55)966 0789
 FAX +81(55)966 9192
 E mail : alpha@micforg.co.jp
 URL : <http://www.micforg.co.jp>

Alpha Novatech, Inc. - a subsidiary of Alpha Company.

473 Sapena Ct. #12 Santa Clara, CA 95054 USA
 PHONE +1(408)567-8082
 FAX +1(408)567-8053
 E mail : sales@alphanovatech.com
 URL : <http://www.alphanovatech.com>

DATA

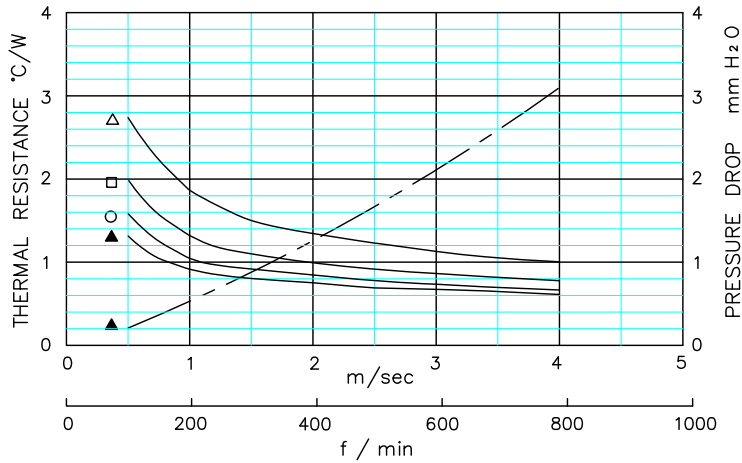

- △ QUBR60-10B
- QUBR60-15B
- QUBR60-20B
- ▲ QUBR60-25B

- DUCTED CONDITION
DUMMY HEATER SIZE: 12.7 SQ
THERMAL RESISTANCE _____
PRESURE DROP - - - - -
- BASED ON ALPHA'S STANDARD TEST PROCEDURE.
REFER TO TECHNICAL INFORMATION.

AIR VELOCITY: DUCTED CONDITION

REF



MODEL NAME INFORMATION

TO BUILD PART NUMBER, PLEASE VISIT OUR WEBSITE www.micforg.co.jp OR CONTACT ALPHA SALES.

Alpha Company Ltd.

256-1 UEDA, NUMAZU-CITY SHIZUOKA-PREF., JAPAN
 PHONE +81(55)966 0789
 FAX +81(55)966 9192
 E mail : alpha@micforg.co.jp
 URL : <http://www.micforg.co.jp>

Alpha Novatech, Inc. - a subsidiary of Alpha Company.

473 Sapena Ct. #12 Santa Clara, CA 95054 USA
 PHONE +1(408)567-8082
 FAX +1(408)567-8053
 E mail : sales@alphanovatech.com
 URL : <http://www.alphanovatech.com>